

PROPER GUTTER AND DOWNSPOUT SIZING

DESIGN OF ROOF DRAINAGE SYSTEMS ROOF DRAINAGE

The roof is one of the most essential parts of a building as it protects occupants, contents, and interior of the structure from the elements. Once an architect has determined the kind of roof he intends to use, he must give equal attention to the design of the roof drainage system.

Factors to be considered in the design of roof drainage systems are the area to be drained, size of gutters, downspouts, outlets, slope of roof, type of building, and appearance.

ROOF AREA TO BE CONSIDERED

The design capacity for a roof drainage system depends on the quantity of water to be handled. The quantity of water in turn depends on the roof area, slope, and rainfall intensity.

In considering the roof area, it must be remembered that rain does not necessarily fall vertically and that maximum conditions exist only when rain falls perpendicular to a surface. Since the roof area would increase as its pitch increases, then it would not be advisable to use the plan area of a pitched roof in the calculation of a drainage system.

Experience has taught that use of the true area of a pitched roof often leads to oversizing of gutters, downspouts, and drains. To determine the design area for a pitched roof, Table 1-1 is used.

**TABLE 1-1
DESIGN AREAS FOR PITCHED ROOFS**

in./ft.	PITCH	*B
	mm/mm	
Level to 3	76/305	1.00
4 to 5	102-127/305	1.05
6 to 8	152-203/305	1.10
9 to 11	229-279/305	1.20
12	305/305	1.30

* To determine the design area multiply the plan area by the factor in B column

These areas are then divided by the proper factor given in Table 1-2, thus obtaining the required area in square inches (square mm) for each downspout. From Table 1-3 select the downspout.

RAINFALL INTENSITY - DOWNSPOUT CAPACITY

Rainfall intensity is usually given in inches per hour for a five minute duration or one hour duration based on U.S. Weather Bureau records. Table 1-2 based on records through 1978, gives five minute intensities for selected cities. New Orleans, Los Angeles, for example, may have 8 in./hr.(203 mm/hr) for a five minute duration yet record only 4.8 in. (121 mm) in an hour over a 100 year period. These rates correspond to 0.133 in./min.(3.4 mm/min.) and 0.08 in./min.(2 mm/min.). Local codes may require that drainage systems only be designed for the latter. It takes 96.15 square feet(8.93 square meters) of surface with 1 inch per hour(25 mm/hr) of water to correspond with 1 gpm (0.063 l/s) flow rate. Downspouts and gutters are sized in relation to rainfall on this basis.

Plumbing codes typically use the vertically projected roof area for drainage design and they often use a square foot allowance per square inch of downspout for 1 in./hr.(25 mm/hr) rainfall that varies with diameter, for example, 3 in.(76 mm): 911(85); 4 in.(102 mm): 1100 (102); 5 in.(127 mm): 1280 (119); 6 in.(152 mm): 1400 (130) and 8 in.(203 mm): 1750 (163) sq. ft.(sq. m). Net drainage capacity from using Table 1-1 and 1-2 should be compared with local code requirements.

DOWNSPOUT SIZING

In sizing downspouts, the following considerations apply:

1. Downspouts of less than 7.00 sq in.(4515 sq mm) cross section should not be used except for small areas such as porches and canopies.
2. The size of the downspout should be constant throughout its length.
3. Downspouts should be constructed with conductor heads every 40 ft(12.2 m) to admit air and prevent vacuum.
4. Offset of more than 10 ft(3.0 m) can affect drainage capacity.
5. The gutter outlet capacity should suit the downspout capacity.
6. The downspout size must suit the bottom width of the gutter.

PROPER GUTTER AND DOWNSPOUT SIZING

**TABLE 1-2
RAINFALL DATA AND DRAINAGE FACTORS**

	A STORMS WHICH SHOULD BE EXCEEDED ONLY ONCE IN 10 YEARS				B STORMS WHICH SHOULD BE EXCEEDED ONLY ONCE IN 100 YEARS			
	Intensity lasting 5 minutes		Calculated roof area drained per downspout area		Intensity lasting 5 minutes		Calculated roof area drained per downspout area	
	in/hr	mm/hr	sq/ft sq in	sq m/ 100 sq mm	in/hr	mm/hr	sq/ft sq in	sq m/ 100 sq mm
ALABAMA: Birmingham	7.5	191	160	2.30	10.1	256	120	1.7
Mobile	8.2	208	150	2.10	10.8	274	110	1.6
ALASKA: Fairbanks	2.1	53	570	8.30	3.8	97	310	4.5
Juneau	1.7	43	700	10.10	2.3	57	530	7.60
ARIZONA: Phoenix	5.6	141	220	3.10	8.8	224	140	2.00
Tucson	6.1	155	200	2.80	9.1	232	130	1.90
ARKANSAS: Bentonville	7.4	187	160	2.30	10.2	259	120	1.70
Little Rock	7.4	187	160	2.30	10.0	253	120	1.70
CALIFORNIA: Los Angeles	4.9	124	250	3.50	6.7	170	180	2.60
Sacramento	2.5	64	480	6.90	3.9	100	310	4.40
San Francisco	2.7	68	450	6.4	3.7	93	330	4.70
San Diego	2.2	57	540	7.80	3.1	78	390	5.60
COLORADO: Denver	5.7	146	210	3.00	9.1	232	130	1.90
Boulder	6.4	164	190	2.70	9.4	238	130	1.80
CONNECTICUT: Hartford	6.2	158	190	2.8	8.7	221	140	2.00
DISTRICT OF COLUMBIA	7.1	180	170	2.4	9.7	247	120	1.80
FLORIDA: Jacksonville	7.9	200	150	2.20	10.1	256	120	1.70
Miami	7.7	195	160	2.20	9.8	250	120	1.80
Tampa	8.3	212	140	2.10	10.8	274	110	1.60
GEORGIA: Atlanta	7.3	186	160	2.4	9.9	251	120	1.70
HAWAII: Honolulu	8.7	221	140	2.00	12.0	305	100	1.40
Kahului	7.0	177	170	2.50	12.0	305	100	1.40
Hilo	17.4	442	70	1.00	19.2	488	60	0.90
Lihue	10.4	265	110	1.70	14.4	366	80	1.20
IDAHO: Boise	1.8	46	660	9.50	3.3	84	360	5.20
ILLINOIS: Chicago	6.8	172	180	2.60	9.3	236	130	1.90
INDIANA: Indianapolis	6.8	173	180	2.50	9.4	239	130	1.80
IOWA: Des Moines	7.3	186	160	2.40	10.3	262	120	1.70
KANSAS: Wichita	7.5	191	160	2.30	10.5	267	110	1.60
KENTUCKY: Louisville	6.9	175	170	2.50	9.4	238	130	1.80
LOUISIANA: New Orleans	8.3	211	140	2.10	10.9	277	110	1.60
MAINE: Portland	5.4	136	220	3.20	7.6	192	160	2.30
MARYLAND: Baltimore	7.1	181	170	2.40	9.7	247	120	1.80
MASSACHUSETTS: Boston	5.3	134	230	3.3	7.2	183	170	2.40
MICHIGAN: Detroit	6.4	162	190	2.70	8.9	226	140	1.90
MINNESOTA: Minneapolis	7.0	178	170	2.50	10.0	253	120	1.70

PROPER GUTTER AND DOWNSPOUT SIZING

**TABLE 1-2
RAINFALL DATA AND DRAINAGE FACTORS (Continued)**

	A STORMS WHICH SHOULD BE EXCEEDED ONLY ONCE IN 10 YEARS				B STORMS WHICH SHOULD BE EXCEEDED ONLY ONCE IN 100 YEARS			
	Intensity lasting 5 minutes		Calculated roof area drained per downspout area		Intensity lasting 5 minutes		Calculated roof area drained per downspout area	
	in/hr	mm/hr	sq/ft sq in	sq m/ 100 sq mm	in/hr	mm/hr	sq/ft sq in	sq m/ 100 sq mm
MISSOURI: Kansas City	7.4	187	160	2.30	10.4	265	110	1.70
Saint Louis	7.1	181	170	2.40	9.9	251	120	1.70
MONTANA: Helena	1.8	46	660	9.50	3.1	77	390	5.70
Missoula	1.8	46	660	9.50	2.4	61	500	7.20
NEBRASKA: Omaha	7.4	188	160	2.30	10.5	267	110	1.60
NEVADA: Reno	2.3	57	530	7.60	4.5	114	270	3.90
Las Vegas	2.1	53	570	8.3	5.2	133	230	3.30
NEW JERSEY: Trenton	6.7	170	180	2.60	9.3	236	130	1.90
NEW MEXICO: Albuquerque	4.0	102	300	4.30	6.7	171	180	2.60
Santa Fe	4.5	115	270	3.80	6.4	169	180	2.60
NEW YORK: Albany	6.5	165	190	2.70	9.1	232	130	1.90
Buffalo	6.0	152	200	2.90	8.4	213	140	2.10
New York City	6.7	169	180	2.60	9.2	235	130	1.90
NORTH CAROLINA: Raleigh	7.3	185	160	2.40	9.8	250	120	1.80
NORTH DAKOTA: Bismark	6.6	167	180	2.60	9.8	250	120	1.80
OHIO: Cincinnati	6.8	172	180	2.50	9.3	236	130	1.90
Cleveland	6.3	160	190	2.70	8.8	223	140	2.00
OKLAHOMA: Oklahoma City	7.6	193	160	2.30	10.5	267	110	1.60
OREGON: Baker	2.2	56	550	7.90	3.8	97	310	4.50
Portland	2.1	53	570	8.30	3.0	76	400	5.80
PENNSYLVANIA: Philadelphia	6.8	172	180	2.60	9.4	238	130	1.80
Pittsburgh	6.4	163	190	2.70	8.8	224	140	2.00
RHODE ISLAND: Providence	5.6	143	210	3.10	7.8	198	150	2.20
SOUTH CAROLINA: Charleston	7.2	184	170	2.40	9.4	238	130	1.80
TENNESSEE: Memphis	7.4	187	160	2.30	10.0	253	120	1.70
Knoxville	6.7	169	180	2.60	9.0	229	130	1.90
TEXAS: Fort Worth	7.6	193	193	160	10.5	267	110	1.60
Dallas	7.6	194	160	2.30	10.5	267	110	1.60
Houston	8.2	208	150	2.10	10.8	274	110	1.60
San Antonio	7.6	193	160	2.30	10.5	267	110	1.60
UTAH: Provo	3.0	75	410	5.80	5.2	131	230	3.30
Salt Lake City	2.8	71	430	6.20	4.3	108	280	4.10
VIRGINIA: Norfolk	7.1	181	170	2.40	9.5	242	130	1.80
WASHINGTON: Seattle	2.1	53	570	8.30	3.3	84	360	5.20
Spokane	2.1	53	570	8.30	3.5	90	340	4.90
WEST VIRGINIA: Parkersburg	6.6	168	180	2.60	9.1	230	130	1.90
WISCONSIN: Madison	6.8	172	180	2.50	9.5	241	130	1.80
Milwaukee	6.6	168	180	2.60	9.1	232	130	1.90
WYOMING: Cheyenne	5.7	146	210	3.00	9.9	252	120	1.70

These intensities are based on records and statistical projections. They may occasionally be exceeded either in the general area or at small areas within the designated city.

TECHNICAL REFERENCE APPENDIX

PROPER GUTTER AND DOWNSPOUT SIZING

**TABLE 1-3
DIMENSIONS OF STANDARD DOWNSPOUTS**

TYPE	AREA		"A" Size		Nominal Size		Actual	
	sq.in.	sq.mm.	sq.in.	sq.mm.	in.	mm.	in.	mm.
Plain Round	7.07	4560	5.94	3831	3	76	3	76
	12.57	810	11.04	7120	4	102	4	102
	19.63	12661	17.71	11422	5	127	5	127
	28.27	18234	25.95	16737	6	152	6	152
	50.24	32404	47.15	30411	8	203	8	203
Corrugated Round	5.94	3831			3	76	3	76
	11.04	7120			4	102	4	102
	17.72	11429			5	127	5	127
	25.97	16750			6	152	6	152
Plain Rectangular	3.94	2541	3.00	1935	2	51	1.75x2.25	44x57
	6.00	3870	4.80	3096	3	76	2x3	51x76
	12.00	7740	10.31	6649	4	102	3x4	76x102
	20.00	12900	15.75	10158	5	127	3.75x4.75	95x121
	24.00	15480	21.56	13906	6	152	4x6	102x152
Rectangular Corrugated	3.80	2451	3.00	1935	2	51	1.75x2.25	44x57
	7.73	4985	6.38	4155	3	76	2.37x3.25	60x83
	11.70	7621	10.00	6513	4	102	2.75x4.25	70x108
	18.75	12213	16.63	10832	5	127	3.75x5	95x127

"A" = area of 1/4 in.(6.4 mm) undersized inlet See Figures 1-31 and 1-32 for gage

7. Assuming that using the fewest number of downspouts is desirable, their locations will be affected by

a. gutter capacity and length. To limit the effects of thermal expansion in gutters 50 ft(15.3 m) is a practical maximum length of gutter to be served by a downspout. Unless special provisions are made for flexibility in downspouts, gutters and their support systems, gutters should expand away from downspouts and downspouts should not be located near gutter expansion joints. See expansion coefficients in Appendix A-1 and expansion allowances in Figures 1-5 to 1-10.

b. the capacity of the inlet tube. See Table 1-3 and Figure 1-33. Also, a sharp bend at the inlet may clog.

c. potential for water freezing in downspouts and gutters. Open, partially open or corrugated styles downspouts are suggested for areas subject to icing. Locating downspouts on the north side of buildings is not recommended for such areas.

d. the appearance of the downspout system and a potential need for concealment. See Figures 1-31 and 1-32.

e. the greater capacity of a pitched gutter.

f. the downspout discharge location. Water disposal at this location should be acceptable. See Figures 1-31 and 1-36.

g. the risk of gutter overflow from insufficient drainage capacity. See Figures 1-4, 1-21, and 1-23.

h. a scupper serving a designated roof area. See Figures 1-26 to 1-30.

After the number and location of downspouts have been determined, the areas to be drained by each downspout

should be figured. In making this calculation for a pitched roof, the plan area should be adjusted according to recommendations given on Table 1-1.

SAMPLE PROBLEM: Select downspouts for a building in Boston, Mass. The building is 100 x 85 ft.(30.5 x 26 m) with a double pitched roof having a slope of 6 in./ft.(152 mm/m). The slope is toward the 100 ft.(30.5 m) side. Maximum rainfall conditions will be used to determine downspout size.

It is decided to drain the building with 4 downspouts located at each corner of the building. An expansion joint will be installed in each gutter between the downspouts.

The plan area of this building is 8500 sq ft.(790 sq m). Since the slope is 6 in./ft.(152 mm/m), factor 1.10 is used (Table 1-1), making the design area 9350 sq ft.(868 sq m). Thus each of the four downspouts will serve a 2338 sq ft.(217 sq m) area. From column B, Table 1-2, opposite Boston, it is found that 1 sq in.(645 sq mm) of downspout will drain 170 sq ft.(16 sq m) of roof area. Divide 2338(217) by 170(16) to determine that each downspout should have a minimum area of 13.56 sq in.(8746 sq mm).

From Table 1-3, it is found that there is a choice of; a 5 in.(127 mm) Plain Round, a 5 in.(127 mm) Corrugated Round, a 5 in.(127 mm) Rectangular Corrugated, or 5 in.(127 mm) Plain Rectangular downspout.

TECHNICAL REFERENCE APPENDIX

PROPER GUTTER AND DOWNSPOUT SIZING

GUTTER SIZING

In sizing gutters, the following considerations apply for typical section lengths of 8 to 10 feet(2.41 to 3.0 m):

1. Spacing and size of outlet openings. (The gutter can never be any more effective than the outlet and downspout selected to drain it. Downspout sizes must not exceed the bottom width of the gutter.)
2. Slope of the roof. (The gutter must be of such a design and location that water from a steep pitched roof will not by its own velocity tend to overrun the front edge.)
3. Style of gutters to be used. (All gutters are not effective for their full depth and width, see Figures 1-1 and 1-4 for design data.)
4. Maximum length of gutter. (50 ft.(15.2 m) between ends or expansion joints is the limit unless the system is especially designed to accommodate the greater expansion, the larger flow and the need for special supports.)
5. Gutter support capability. (Supports should be based on full capacity of the gutter. Ice load capacity also affect the size and strength of the system.)

Level gutters may be sized by Charts 1-1, 1-2, or 1-3. Sloped gutters may be sized by Chart 1-3. Formulae for flow in gutters with different pitch are not available. The capacity of a gutter with 1/16 in./ft.(5.21 mm/m) or less pitch is taken as that of a level gutter even though it is somewhat greater.

RECTANGULAR GUTTER SIZING

The size of rectangular gutters depends upon these factors:

1. Area to be drained. (A, Chart 1-1)
2. Rainfall intensity per hour. (I, Chart 1-1)
3. Length of gutter in ft.(m) (L, Chart 1-1)
4. Ratio of depth to width of gutter. (M, Chart 1-1)

Chart 1-1 is based on level gutter capacity as experimentally determined by the National Institute of Standards and Technology (NIST) formerly National Bureau of Standards. It is plotted from $W = 0.0106 M^{-4/7} L^{3/28} (1A)^{5/14}$ with W in feet(m).

IRREGULAR CROSS SECTION GUTTER SIZING

The required sizes of gutters other than rectangular or round can be determined by finding the semicircle or rectangular area that most closely fits the irregular cross section.

HALF ROUND GUTTER SIZING

Chart 1-2 is based on level gutter capacity as determined by NIST. It is based on $W = 0.0182 (IA)^{2/5}$. W is the width in in.(mm). I denotes rainfall intensity (Table 1-2) and A is the roof area in square feet(sq m) (Table 1-1).

SAMPLE PROBLEM: To size rectangular gutter for a building 120 x 30 ft.(35.6 x 9.1 m) located in Buffalo, NY. This building has a flat roof with a raised roof edge on three sides. A gutter is to be located on one of the 120 ft.(35.6 m) sides. So that each section of gutter will not exceed 50 ft.(15.2 m), three downspouts will be used with 2 gutter expansion joints. The area to be drained by each section of gutter will be 1200 sq ft.(111.5 sq m), the rainfall intensity from Table 1-2, col A is 6 in/hr(152 mm/hr), the length of each gutter section is 40 ft.(12.2 m), and the ratio of gutter depth to width is 0.75. On Chart 1-1 find the vertical line representing L = 40(12.2 m). Proceed vertically along this line to its intersection with the oblique line representing M = 0.75. Pass to B vertically to the intersect the horizontal line representing IA = 7200(16948). The point of intersection occurs between the oblique line representing gutter widths of 5 and 6 in.(127 and 152 mm). The required width of gutter is, therefore, 6 in.(152 mm) and its depth need be only 4.5 in.(114 mm).in.

SAMPLE PROBLEM: To size a half round gutter for a building, located in Kansas City, Mo., with a flat roof 80 x 40 ft.(24.4 x 12.2 m). This building has a parapet wall on three sides and a gutter to be located on an 80 ft.(24.4 m) side. Column A, Table 1-2, was used to determine rainfall conditions. Since the gutter run will exceed 50 ft.(15.2 m), two downspouts will be used with an expansion joint between.

The area of the building is 3200 sq ft.(297 sq m). Thus each of the downspouts will serve an area of 1600 sq ft. (149 sq m). From column A, Table 1-2, opposite Kansas City, Mo., it is found that 1 sq in.(100 sq mm) of downspout will drain 160 sq ft.(2.3 sq m/100 sq mm) of roof area. Divide 1600 sq ft.(149 sq m) by 160 sq ft/sq in.(2.3 sq m/100 sq mm) to determine that each downspout should have a minimum area of 10 sq in.(6470 sq mm). From Table 1-3 it is found that a 4 in.(102 mm) downspout is required. From Chart 1-2 it is determined that a 9.5 in.(241 mm) half round gutter should be used. Area and flow in Table 1-4 are based on 1 in.(25 mm) of rainfall per hour; divide these areas by the local rainfall rate in inches per hour to determine the actual roof area to be served by the gutter diameter. "The capacity of a sloped rectangular gutter may be approximated by using a gutter cross section area not less than that of a semicircular gutter and a depth to width ratio of at least 0.75.

PROPER GUTTER AND DOWNSPOUT SIZING

CHART 1-1
WIDTH OF RECTANGULAR GUTTERS FOR GIVEN ROOF AREAS
AND RAINFALL INTENSITIES

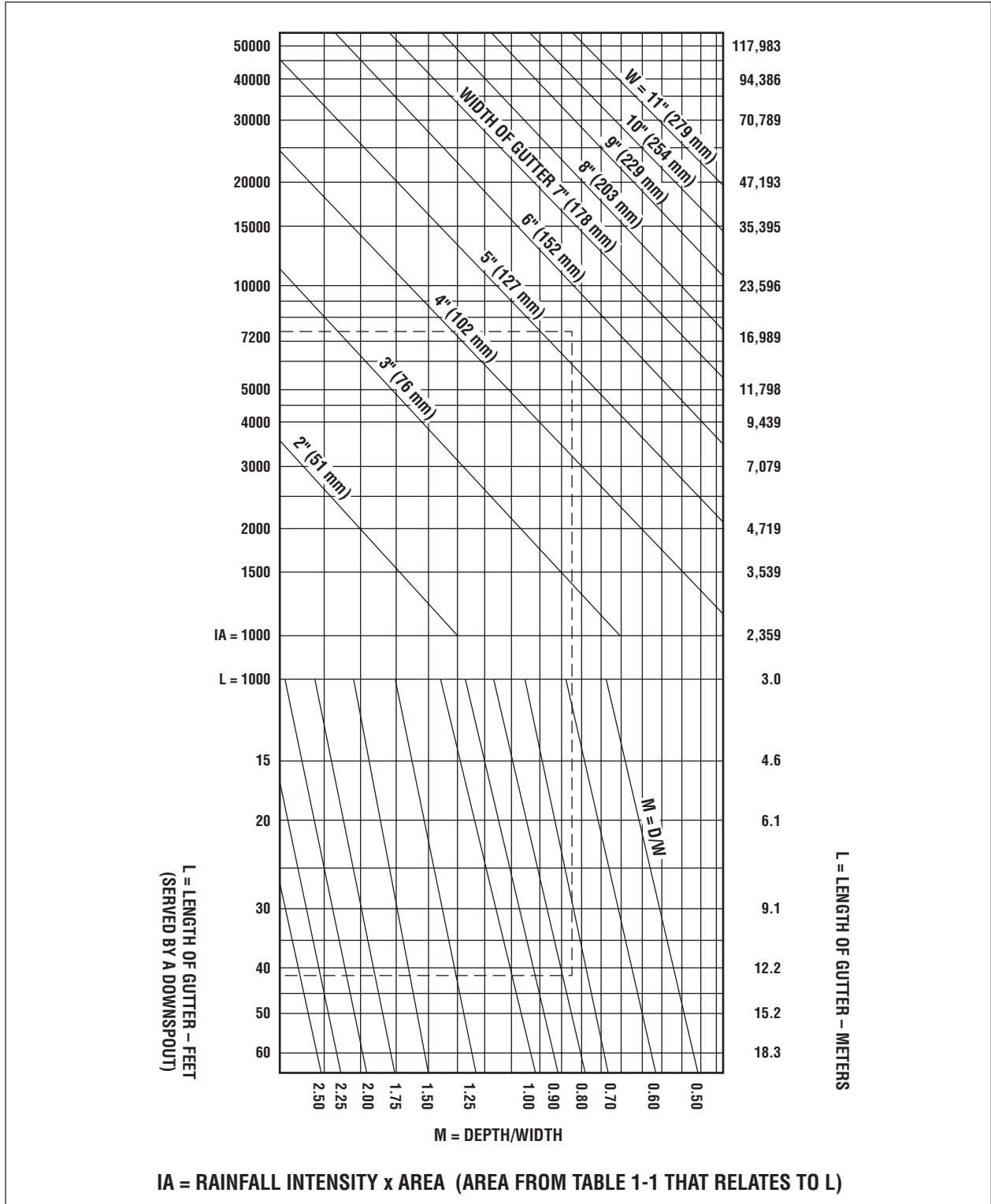

PROPER GUTTER AND DOWNSPOUT SIZING

CHART 1-2
HALF ROUND GUTTER SELECTION
Width required for given roof areas and rainfall intensities

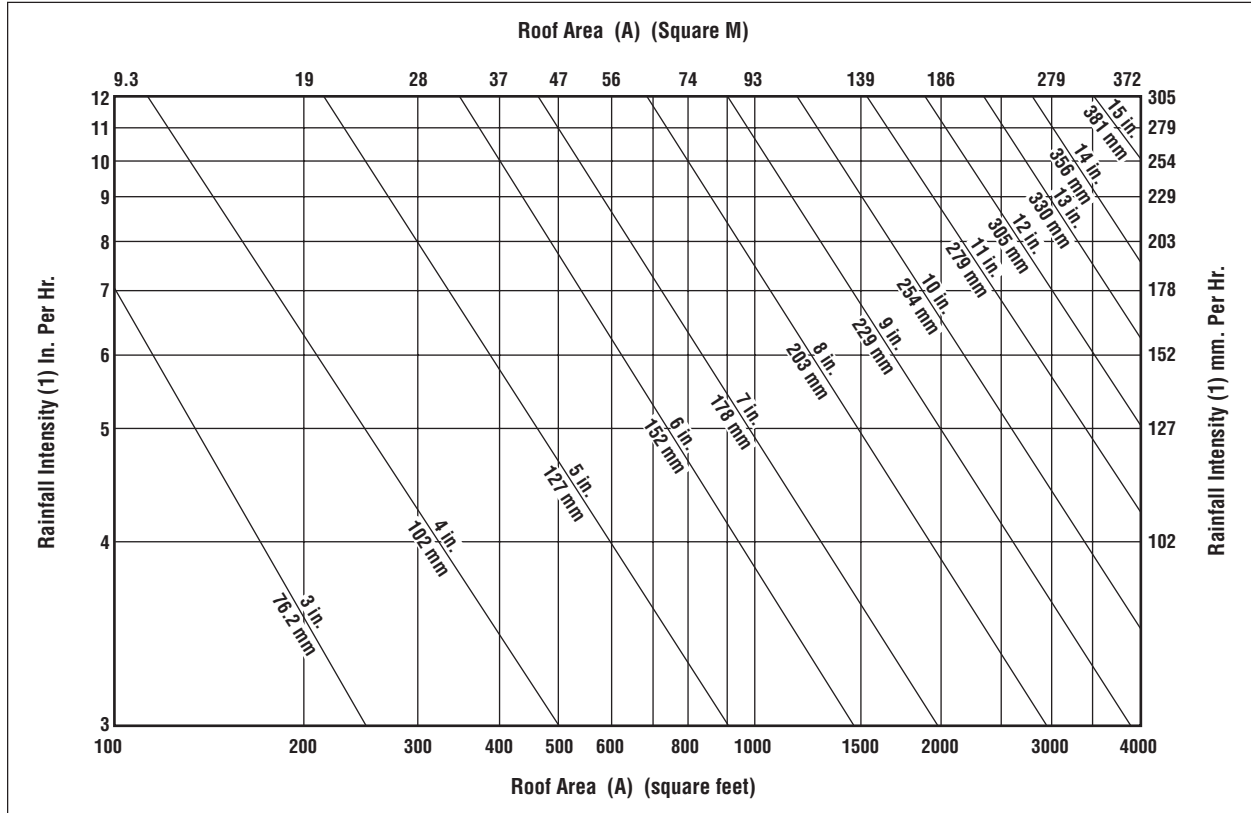

TABLE 1-4
SLOPED ROOF GUTTERS
Maximum Roof Area for Gutters

Diameter of gutter		C.S. Area		Level		Level		1/8 in per ft slope (3.2 mm/.3 m)				1/4 in per ft slope (6.4 mm/.3 m)			
in	mm	sq in	sq mm	sq ft	sq m	gpm	l/s	sq ft	sq m	gpm	l/s	sq ft	sq m	gpm	l/s
3	76	3.5	2258	680	63	7	0.44	960	89	10	0.63	1360	126	14	0.88
4	102	6.3	4064	1440	134	15	0.95	2040	190	21	1.33	2880	268	30	2.08
5	127	9.8	6321	2500	232	26	1.64	3520	327	37	2.33	5000	465	52	3.28
6	152	14.1	9095	3840	357	40	2.52	5440	505	57	3.60	7680	713	80	5.05
7	178			5520	513	57	3.60	7800	725	81	5.11	11040	1030	115	7.26
8	203	25.1	16190	7960	739	83	5.24	11200	1040	116	7.32	14400	1338	165	10.4
10	254	39.1	25220	14400	1338	150	9.47	20400	1895	212	13.4	28800	2676	299	18.9

TECHNICAL REFERENCE APPENDIX

GUTTER HANGER SELECTION

In deciding which hanger style is most acceptable, please consider such things as appearance, expected life, ice loading, size of gutter, material and expansion.

When fascia board is less than 2" thick, the hanger fasteners must be driven into the rafter ends.

In areas subject to snow slide, coordinate the front edge elevation of the gutter with the extended roof line (see Table on Required Clearance of Gutter Below Extended Roof Line).

RECOMMENDED GUTTER HANGER SPACING

Gutter hangers should be spaced at a maximum of 36" on center. In areas where ice and snow are long lasting, hanger spacing should be reduced to 18" on center.

RECOMMENDED GUTTER PITCH AND POSITION ON THE EAVE

There are two factors that go into determining gutter position on the eave, the pitch of the gutter and the roof slope. Gutter should be pitched 1/16" or greater per foot for proper drainage. Gutter can be run level for appearance but addition downspout will be necessary (See section on Proper Gutter and Downspout Sizing).

Gutters should be placed below the extended roof line so that snow and ice can slide clear. Steeper pitches require less clearance.

Required Clearance of Gutter Below Extended Roof Line

Roof Pitch	Clearance Below Extended Roof Line
0 in 12 – 2 in 12	1"
3 in 12 – 5 in 12	3/4"
6 in 12 – 8 in 12	1/2"
9 in 12 or Greater	1/4"

LAP JOINT SPECIFICATION

Joints in gutters must be overlapped 1", riveted on 2" centers and soldered if the metal can be soldered (see soldering instructions for details). With metals that cannot be soldered, a compatible sealant must be continuously applied within a 1" lapped joint and the sealed lap must be riveted on 1" centers. All rivet applications must receive sealant after installation. Lapping joints in the direction of flow is preferred; gutter outlet connections may not fit this condition.

PENETRATING WALL FASTENERS

We recommend drilling holes in masonry and the use of metal hole inserts and/or epoxy sealant when installing these pipe hook fasteners. Wall penetrations need to be sealed to prevent water intrusion and related problems. Driving these into brick mortar joints will cause damage to the pipe hook fasteners and the wall.

TYPICAL GUTTER HANGER DETAILS

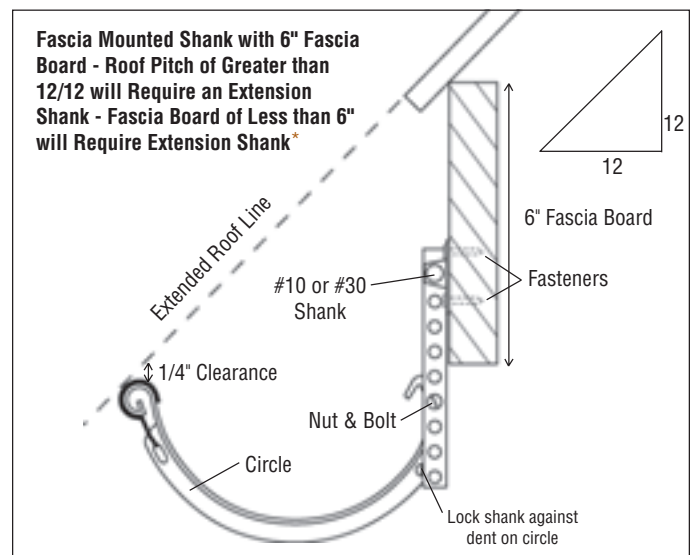
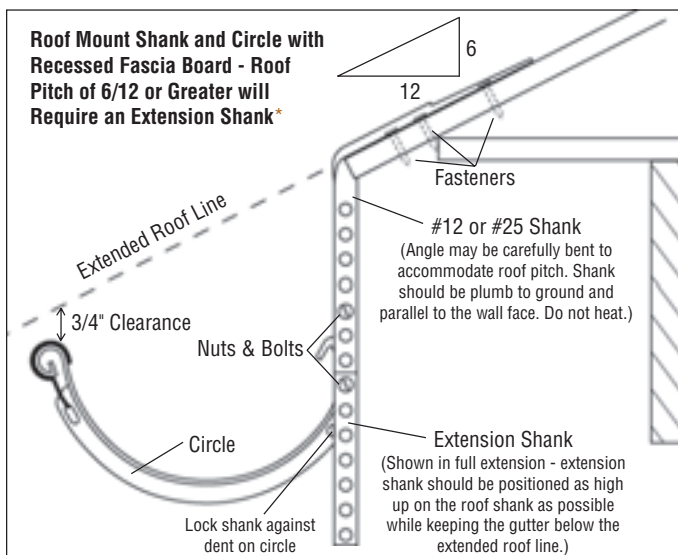
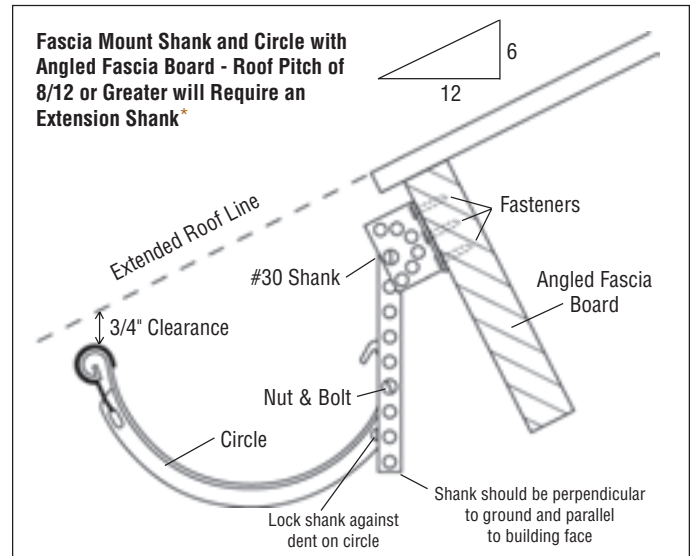
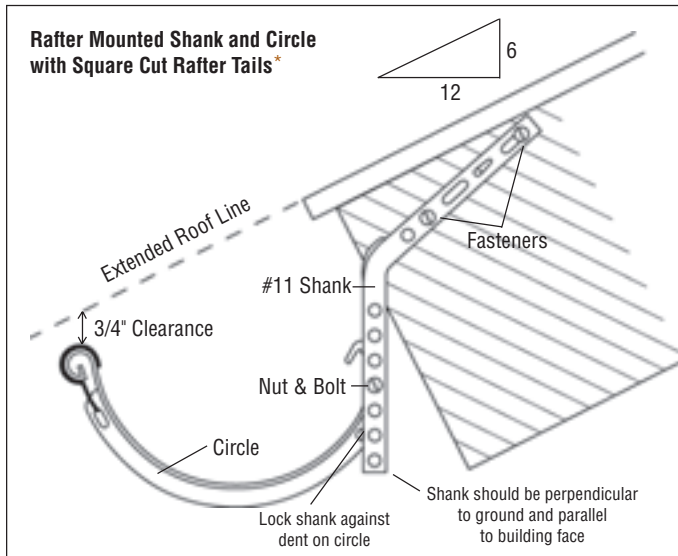
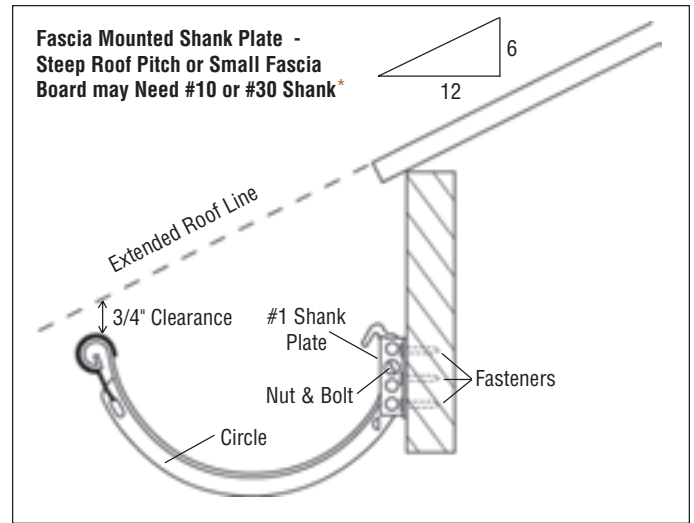
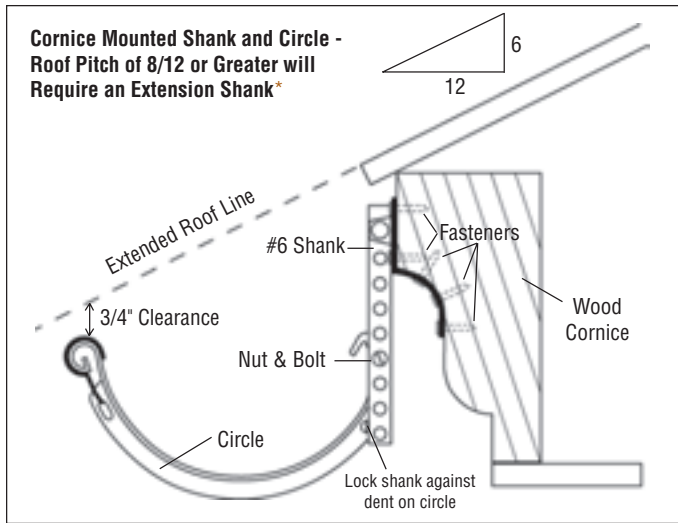

* Only 1 hole will line up with bolt Center distance on shank is 1/2". Center distance on circle is 3/8". This allows the gutter to be pitched by lowering the circle on the shank in increments of 1/8". Berger does not imply fitness of use of our components in conjunction with competitors products. Berger will not warrant any system that incorporates products not manufactured by Berger.

TECHNICAL REFERENCE APPENDIX

EXPANSION OF METALS USED FOR ROOF DRAINAGE

Increase in 50 ft Length of Material Due to an Increase in Temperature of 100° Fahrenheit

	Galvanized Steel	Copper	Stainless Steel	Aluminum	Zinc
Increase (in inches)	13/32"	5/8"	5/8"	25/32"	1 1/32"

Note: Material will decrease in length by the same distances due to a decrease in temperature of 100° Fahrenheit.

Gutter Expansion:

It is essential to provide expansion joints in all gutter installations to allow for movement due to temperature changes. In planning expansion joint locations, it must be recognized that an expansion joint acts as a dam in the gutter, therefore, the number and placement of downspouts will be influenced (see section on Proper Gutter and Downspout Sizing).

No gutter length should exceed 50 ft without an expansion joint. Expansion joints should be installed to comply with the SMACNA Architectural Sheet Metal Manual 5th Edition page 1.16 to 1.17 – Allowances For Gutter Expansion.

There are two types of expansion joints commonly used in gutter installation, Lap Type and Butt Type. Both of these types of expansion joints are easily fabricated on the jobsite using end caps and small amounts of sheet metal. Details for both Lap Type and Butt Type can be found in the SMACNA Architectural Sheet Metal Manual 5th Edition pages 1.18 to 1.21 – Lap Type Expansion Joint Figure 1-6 and Butt Type Expansion Joint Figure 1-7.

BASIC SOLDERING TERMS AND TECHNIQUES

The successful application of soldering requires several elements that include properly tinned coppers, application and type of flux, properly blended solder, type of soldering tip, correctly heated coppers, properly prepared metal surface free of oxidation and the skill of the person applying the solder.

Common Terms

Solder – Any of various fusible alloys, usually made of tin and lead, used to join metallic parts.

Soldering – joining or uniting of two or more pieces of metal by means of an alloy, usually tin and lead, having a lower melting point than the pieces being joined.

Soldering Coppers – an instrument for soldering, consisting of a bit or bolt of copper having a pointed or wedge-shaped end, and furnished with a handle. Soldering Coppers can have various shapes for different kinds of work.

Tinning – covering the point of a soldering copper or other surface with solder.

Flux – A substance applied to a surface to be joined by welding, soldering or brazing to facilitate the flowing of solder and prevent formation of oxides.

Sal Ammoniac – another name for Ammonium Chloride (NH₄Cl), is a white crystalline compound used as a soldering flux.

Zinc Chloride – (ZnCl) A substance, also called cut or killed acid, which is unequalled as a flux when soldering galvanized steel, stainless steel and copper. It is colorless, odorless and corrosive; therefore it should be handled with care.

Muriatic Acid – The commercial grade of Hydrochloric Acid (HCl), also called raw acid, which is used for making Zinc Chloride, used as a flux and for cleaning dirty parts of metal before they are soldered. It is colorless, has a sharp pungent odor and is corrosive; therefore it should be handled with care.

Rosin – The by-product of oil of turpentine that is a common, non-corrosive type of flux for soldering copper. Rosin is usually found in powder or paste form.

Oxide – A compound that is formed on the surface of a metal due to a reaction with the oxygen in the air.

BASIC SOLDERING TERMS AND TECHNIQUES

Preparation

Filing and Tinning Soldering Coppers

Unless the soldering copper is properly tinned, a good soldering job is impossible. Tinning keeps scale and corrosion from forming on the soldering copper point that acts as insulation, allows the solder to flow properly from the point to the metal, and keeps dirt and scale out of both the solder and the seam. For best results, use a 50% Tin – 50% Lead solder.

1. Heat the copper to a cherry red and place it in a vise. Using a coarse file, remove pits and old tinning. Then using a finer file, smooth off the rough edges of the corners of the point.
2. Reheat the copper enough to melt the solder. Apply a small portion of solder to the tip and rub the tip lightly back and forth on a block of Sal Ammoniac. If the solder does not adhere to the point, it is because the soldering copper is not hot enough. Do not inhale the white smoke that should rise from the Sal Ammoniac block. It is a toxic gas and should not be breathed.
3. The solder copper should be neither overheated nor under heated during the tinning operation. If the copper is too hot, the tin will burn off as fast as it is applied. If it is too cold, the solder will not adhere to the copper.

Clean All Surfaces of Oxides, Dirt, Grease, and Other Foreign Matter

Unless the metal that is being soldered is clean, neither the solder nor the flux will adhere to the surface if the metal.

Applying the Soldering Flux

Applying the flux is important. Carelessness in its application will ruin the entire solder procedure.

1. Liquid Fluxes are applied with a small brush. Dip the brush and spread it lightly on the area to be soldered. Do not apply flux anywhere except where the soldering is to be done.
2. Powdered flux, such as rosin may be sprinkled onto the surface to be soldered or it can be melted on to the metal with a hot copper. Do not apply flux anywhere except where the soldering is to be done.
3. Flux will absorb moisture, which weakens its capability. Be sure to use fresh flux that has not been diluted.

Soldering

Position of the Soldering Copper

The position of the soldering copper is important as it is applied to the parent metal because it heats the metal to the melting point of solder and it keeps the solder in a liquid state while soldering.

1. It is important that as much of the point of the copper is resting on the metal as possible to allow maximum heat transfer from the tip to the metal. Most of the heat is in the body and the base of the point of the soldering copper – not in the tip.
2. Since melted solders flow to the hottest point of the metal, have the base of the soldering copper in contact with the area in which the solder is to flow. When soldering a seam, allow the soldering copper to heat the seam itself so solder will flow into the seam for a watertight seal.

BASIC SOLDERING TERMS AND TECHNIQUES / STORAGE AND HANDLING OF PRODUCT

Soldering Different Types of Metal

Different techniques and materials are needed to effectively solder different types of metal.

1. Galvanized Steel

- a. If the galvanized steel is bright and clear, use Zinc Chloride as a flux to make a well-bonded joint.
- b. If the galvanized steel is dull and dirty, use Muriatic Acid as a flux to allow the solder to bond.
- c. For best results, use a 50% Tin – 50% Lead solder.
- d. All flux should be washed off of the metal after soldering is complete.
- e. There are many commercially marketed fluxes for soldering galvanized steel.

2. Copper

- a. If the surface of the copper is free of oxide, it can be easily soldered using Zinc Chloride as a flux.
- b. If the copper is dull, apply Muriatic Acid directly to the metal with an acid brush to clean the surface. The Muriatic Acid should be washed off with a damp rag before applying the Zinc Chloride as a flux.
- c. For best results, use a 50% Tin – 50% Lead solder.
- d. All flux should be washed off of the metal after soldering is complete.
- e. There are many commercially marketed fluxes for soldering copper.

3. Stainless Steel

- a. Apply Muriatic Acid directly to the metal with an acid brush to clean the surface.
- b. Leave the acid on the surface of the metal for the required time (this varies with the type of stainless steel and the strength of the acid).
- c. The Muriatic Acid should be washed off with a damp rag before applying the Zinc Chloride as a flux.
- d. For best results, use a 50% Tin – 50% Lead solder.
- e. All flux should be washed off of the metal after soldering is complete.
- f. There are many commercially marketed fluxes for soldering stainless steel.

STORAGE AND HANDLING OF PRODUCT

Berger products must be stored in a properly ventilated, dry environment to prevent condensation on metal surfaces. Materials that are stored in areas subject to temperature variations, outside storage or subjected to moisture damage are not returnable. Galvanized Steel and Zinc surfaces are susceptible to humid storage stain or white rust. SMACNA guidelines for storage and handling of materials apply. Refer to SMACNA appendix A-5 sections 1.7, 1.8, 1.9.